

Orion 2C/Orion 3A Precision Pneumatic Controllers



Orion 2C cased version 89216 shown with DPDG Gauge and optional adapters 55394 and 120422



Orion 2C cased version 89216 shown with optional quick-disconnect adjustable adapter, 120422



Orion 2C/Orion 3A Cased Controller Literature sheet available - 121189



"120462 - HANDS FREE VIEWING"



"120422 - HANDS FREE VIEWING"

STANDARD FEATURES

- System working pressure:
Orion 2C, non-cased/cased versions:
Up to 3000 psi
Orion 3A, non-cased version: Up to 10,000 psi
Orion 3A, cased version: Up to 10,000 psi based on model
- Orion 2C: Aluminum body, Buna-N o-rings standard
Orion 3A: Stainless steel body, Viton o-rings standard
- Precision patented vernier to precisely "dial in" a selected pressure
- Fingertip closed system pressure adjustment to better than 0.0005 psi
- Soft seat construction and adjustable stop - immune to over tightening
- Two low-torque, fine micro-metering valves with positive shut off
- Two test ports allow for multiple applications:
- Non-cased models (see below for optional seal plug)
- Cased models, # of test ports based on version

APPLICATIONS

- Gas applications
- Operation to 10,000 psi, based on model
- Test stands
- OEM pressure control applications

SPECIFICATIONS ORION 2C

Pressure Range:

0-3000 psi and vacuum

Proof Pressure:

4000 psi

Pressure and Vent Valve Orifice:

0.032

Cv Factor:

0.007

Mechanical Rotation:

3.5 turns, nominal

Torque:

Finger tip adjust

Vernier Volume:

0.5 cubic inch, nominal

Vernier Mechanical Rotation:

16 turns, nominal

Adjustable Sensitivity:

0.0005 psi, minimum

Vernier Torque:

Finger tip adjust to 3000 psi

Construction:

Body: Aluminum, clear anodize
Knobs: Aluminum, black anodize
O-rings: Buna-N standard, others available
Ports:
Orion 2C (uncased version, 55283):
Test port #1, input port and output port -fitting (59716) for 1/8" OD tube
Test port #2, 7/16-20 UNF female (MS33649-04) straight thread. Optional: use one each 68862 & 61035 to plug
Orion 2C (cased version, 89216):
Input port, two test ports and vent port - male 7/16-20 AN-4, stainless steel
All other parts 300 series stainless steel

Case Material

16 gauge painted steel

SPECIFICATIONS ORION 3A

Pressure Range:

0-10,000 psi and vacuum (uncased version, 55287)
0-6000 psi and vacuum (cased version, 159874)
0-10,000 psi and vacuum (cased version, 113949)

Proof Pressure:

15,000 psi (uncased version, 55287)
9000 psi (cased version, 159874)
11,000 psi (cased version, 113949)

Pressure and Vent Valve Orifice:

0.032

Cv Factor:

0.007

Mechanical Rotation:

3.5 turns, nominal

Torque:

Finger tip adjust

Vernier Volume:

0.4 cubic inch, nominal

Vernier Mechanical Rotation:

15 turns, nominal

Adjustable Sensitivity:

0.005 psi, minimum

Vernier Torque:

Finger tip adjust to 10,000 psi

Construction:

Body: 300 series stainless steel
Knobs: Aluminum, black anodize
O-rings: Viton standard, others available
Ports:
Orion 3A (uncased version, 55287)
Test port #1, input port and output port - stainless steel fitting (59731) for 1/8 in. OD tubing
Test port #2, 7/16-20 UNF female (MS33649-04) straight thread. Optional: use one each 68862 & 54854 to permanently plug
Orion 3A (cased version, 159874):
Input port, two test ports and vent port - 7/16-20 AN-4 males, stainless steel
Orion 3A (cased version, 113949):
Input port and two test ports- stainless steel fitting for 1/4 in. OD tubing
Vent port - stainless steel fitting for 1/8 in. OD tubing
All other parts 300 series stainless steel

Case Material

16 gauge painted steel

Orion 2C/Orion 3A Precision Pneumatic Controllers

MODEL/PRICE

PART #	DESCRIPTION	EST. SHIP WEIGHT	PRICE
55283	Orion 2C, vacuum-3K PSI (with Buna-N O-rings) NOTE: to seal test port #2 order 1 ea. 68862 & 61035 or for 1/8 tube fitting order 1 ea. 54854 & 59982	6 lb	Consult
55287	Orion 3A, vacuum-10K PSI (with Viton O-rings) NOTE: to seal test port #2 order 1 ea. 68862 & 54854 or for 1/8 tube fitting order 65485	10 lb	Consult
89216	Cased Orion 2C, vacuum-3K PSI (with Buna-N O-rings) Ports; 2 outputs (1 each front and rear), 1 input, 1 vent, all ports 7/16-20 AN-4 male NOTE: Cheat Seal 54854 used for all ports.	8 lb	Consult
159874	Cased Orion 3A, vacuum-6K PSI (with Viton O-rings) Ports; 2 outputs (1 each front and rear), 1 input, 1 vent NOTE: Cheat Seal 54854 used for all ports.	12 lb	Consult
159875	Cased Orion 3A, vacuum-7500 PSI (with Viton O-rings) Ports; 2 outputs (1 each front & rear 1/8 NPT male), 1 input 1/8 NPT male, 1 vent 7/16-20 AN-4 male	12 lb	Consult
159876	Cased Orion 3A, vacuum-7500 PSI (with Viton O-rings) Ports; 2 outputs (1 each front & rear 1/4 NPT male), 1 input 1/4 NPT male, 1 vent 7/16-20 AN-4 male	12 lb	Consult
113949	Cased Orion 3A, vacuum-10K (with Viton O-rings) Ports; 2 outputs (1 each front & rear) & 1 input for 1/4 tube, 1 vent for 1/8 tube - Note: Replacement Nut/Ferrule Kit order 159958 for output or input port, 160142 for vent port.	12 lb	Consult



55394 or 130239

OPTIONS/ACCESSORIES

PART #	DESCRIPTION	PRICE
68859	Additional adjustment and maintenance manual	Consult
68862	Seal plug for Orion test port #2 (non-cased Orion 2C requires O-ring 61035 Buna-N (STD) or 55596 Viton, non-cased Orion 3A requires one Cheat Seal 54854)	Consult
55596	O-ring, Viton (used with non-cased Orion 2C and seal plug 68862)	Consult
61035	O-ring, Buna-N (used with non-cased Orion 2C and seal plug 68862)	Consult
54854	Cheat Seal (used with non-cased Orion 3A, seal plug 68862, Cased Orion 3A 159874, adapters 120422 and 120462)	Consult
58499	Replacement Orion 2C, Buna-N O-ring kit	Consult
55277	Replacement Orion 3A, Viton O-ring kit	Consult
120422	Test port quick-disconnect adjustable adapter assembly, Female Quick-Disconnect to 7/16-20, 37 degree AN-4 swivel other end, 3000 PSI (for hands-free display reading when used between Orion 2C cased unit Test Port and Hand-Held or Digital Gauge utilizing Quick-Disconnect Fitting PN 55394 or 130239, see pictorial on previous page, requires one Cheat Seal 54854)	Consult
120462	Test port quick-disconnect adjustable adapter assembly, 1/8 NPT Finger Tighten to 7/16-20, 37 degree AN-4 swivel other end, 5000 psig working pressure (for hands-free display reading when used between Orion 2C cased unit test port and Hand-Held or Digital Gauge with 1/8 NPT Female thread, see pictorial on previous page, requires one Cheat Seal 54854)	Consult
55394	Standard output (test) port quick-disconnect fitting, male coupling body/female 1/4 NPT, 5000 psig working pressure (for mating between DUT, Hand-Held or Digital Gauge and UPC5000 or Source 3000 (PN 65315))	Consult
130239	Output (test) port quick-disconnect fitting, male coupling body/female 1/8 NPT, 6500 psig working pressure (for mating between DUT, Hand-Held or Digital Gauge and UPC5000 or Source 3000 (PN 65315))	Consult

Please consult factory for availability of these non-standard O-ring materials:
Ethylene-propylene Neoprene Silicone

Consult factory for Orion 3A (cased or non-cased version) dimensions.

Orion 2C/Orion 3A Precision Pneumatic Controllers

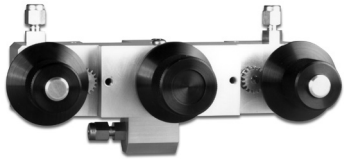

Orion 2C



Orion 3A

Test Port #2, see Options/Accessories

Test Port #2, see Options/Accessories

ORION 2C NON-CASED VERSION
PN 55283

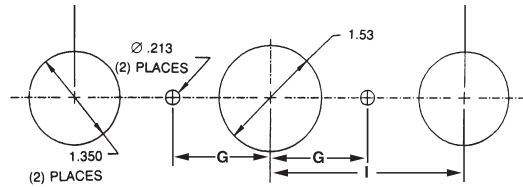
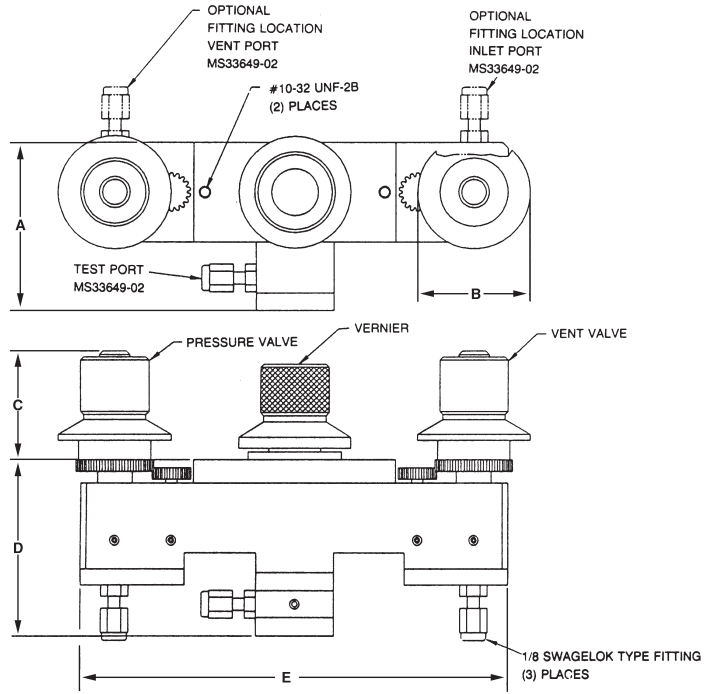

RECOMMENDED HOLE PATTERN FOR ORION 2C

ORION 2C NON-CASED DIMENSIONS	
A	2.70 in. (68.58 mm)
B	1.82 in. (46.22 mm)
C	1.75 in. (44.45 mm)
D	2.80 in. (71.12 mm)
E	6.90 in. (175.26 mm)
F	5.80 in. (147.32 mm)
G	1.45 in. (36.83 mm)
I	2.90 in. (73.66 mm)

ORION 2C CASED DIMENSIONS	
A	8.14 in. (206.75 mm)
B	5.70 in. (144.78 mm)
C	0.30 in. (7.62 mm)
D	1.50 in. (38.10 mm)
E	6.10 in. (154.94 mm)
F	0.80 in. (20.32 mm)
G	0.60 in. (15.24 mm)
H	1.15 in. (29.21 mm)

ORION 2C CASED VERSION
PN 89216

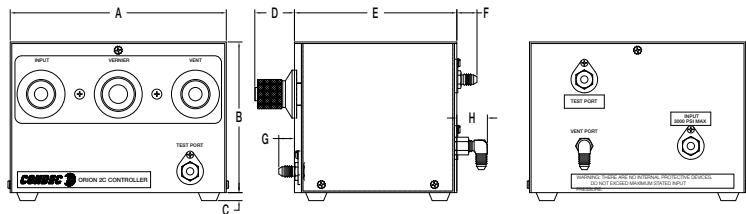

Consult factory for Orion 3A (cased or non-cased version) dimensions.